

Robust CPI design and manufacturing, combined with plenty of thermal margin, results in a GaN SSPA/BUC that is rock-solid, highly efficient and easy to maintain.

High Linearity

Excellent AM/PM, phase noise and spectral regrowth performance.

Simple to Operate

User-friendly microprocessor-controlled logic with Ethernet computer interface (serial interface optional). Also contains digitally controlled attenuator. Redundant systems available. SNMP enabled (v1, v2, or v3).

Global Applications

Perfect for LEO/MEO/GEO systems, Satcom on the Move, VSATs, and antenna-mount applications. Meets Electromagnetic Compatibility Directive 2014/30/EU to satisfy worldwide requirements and is CE-marked.

Worldwide Support

Backed by over 40 years of satellite communications experience, and CPI's worldwide 24-hour customer support network that includes more than 20 regional factory service centers.



CPI GaNLink 160 W Ka-band GaN SSPA/BUC, Model B5KO

FEATURES:

- EMC Directive 2014/30/EU
- Harmonic Standard EN-61000-3-2
- Ethernet interface with integral web server for easy monitoring and control
- SNMP interface (v1, v2, v3)
- Redundant switch controller (SIM)

OPTIONS:

- L-band to Ka-band block upconverter, with multiplexed 10 MHz and 50 MHz reference
- Multiband BUC: select from multiple factory-set frequency bands within the Ka-band frequency range
- Simultaneous multiple BUC: transmit two channels at once using factory set frequency bands (contact CPI for specifications and dimensions)
- Remote control panel
- Serial interface
- Legacy redundant switch controller

Quality Management
System - ISO 9001:2015



Specifications	Model B5KO SSPA	Model B5KO BUC
ELECTRICAL SPECIFICATIONS		
RF Output Frequency	27.5 to 30.0 GHz, 30.0 to 31.0 GHz	Up to 1 GHz within the 27.5 to 31.0 GHz frequency band (multi-band BUCs are also available)
L-Band Input (BUC option only)	N/A	950 to 1450 MHz or 1000 to 1500 MHz, 500 MHz option 950 to 1950 MHz or 1000 to 2000 MHz, 1000 MHz option
Output Power (at the flange) Peak Linear (Plin) Maximum CW	160 W typical (52.0 dBm) from 27.5 to 30.0 GHz, 128 W (51.1 dBm) min. from 30 to 31 GHz See the linear performance table below 112 watts (50.5 dBm) max. from 27.5 to 30.0 GHz, 89 W (49.5 dBm) from 30 to 31 GHz	
Gain	60 dB min, 70 dB max.	
Gain Stability Over temp. constant drive Over 24 hours, fixed temp.	±1.5 dB max. ±0.25 dB	±2.5 dB max. ±0.25 dB
Gain Variation Across 500 MHz Across 2500 MHz	2.0 dB max. 3.5 dB max.	4.0 dB max. 4.5 dB max.
Small Signal Gain Slope	±0.04 dB/MHz max.	
Gain Adjustment Range	16 dB	25 dB
Input VSWR / Output VSWR	1.5:1 max. (50 ohms) / 1.30:1 max.	
Load VSWR	2.0:1 continuous operation; 1.5:1 full spec. compliance	
Reference	N/A	10 MHz
Phase Noise External Reference	N/A	-120 dBc/Hz at 10 Hz; -140 dBc/Hz at 100 Hz; -145 dBc/Hz at 1 kHz; -150 dBc/Hz at ≥10 kHz
Single Sideband Phase Noise	N/A	3 dB better than IESS 308/309 phase noise profile
AM/PM Conversion	2.0°/dB max. for a single carrier at rated linear power	
Harmonic Output	-60 dBc max. at rated power	
Spurious Response at P(lin)	-60 dBc max. at rated power	
Noise Power Density	<-150 dBW/4 kHz, receive band; <-65 dBW/4 kHz, passband	
Prime Power	100 to 264 VAC single phase, 47 to 63 Hz	
Power Consumption	1200 VA max (1000 VA typ. at linear power)	

LINEAR PERFORMANCE		Linear Power (Plin)			
		27.5 to 30.0 GHz		30 to 31 GHz	
		dBm	Watts	dBm	Watts
3rd-Order Intermodulation Products With Regard to Each of Two Carriers	-25 dBc	47.0	50.1	46.0	40.0
3rd-Order Intermodulation Products With Regard to the Sum of Both Carriers	-25 dBc	50.4	109.5	49.5	89.1
Spectral Regrowth @ 1.0 S.R. QPSK	-30 dBc max.	48.0	63.1	46.0	40.0
	-25 dBc	50.0	100.0	48.0	65.0
Noise Power Ratio (NPR)	19 dB min.	48.1	65.0	47.1	51.3
	25 dB min.	44.7	29.5	43.8	24.0

10880 Wilshire Blvd Los Angeles CA 90024 USA

Phone: +1.888.315.9545

Email: contact@orbitalconnect.com

<https://store.orbitalconnect.com>



	Model B5KO SSPA	Model B5KO BUC
MECHANICAL AND ENVIRONMENTAL SPECIFICATIONS		
Ambient Temperature	-40°C to +55°C operating; -54°C to +71°C non-operating	
Relative Humidity	100% condensing	
Altitude	10,000 feet (3048 m) with standard adiabatic derating of 2°C per 1000 feet (305 m), operating; 50,000 feet (15,240 m), non-operating	
Cooling	Integral forced air	
Shock and Vibration	20 g pk, 11 msec, 1/2 sine; 2.1 grms, 5 to 500 Hz	
RF Output Connection	WR34 grooved waveguide flange (WR28 optional)	
Input Connection	2.9 mm female	Type N female (L-band input)
M&C Interface	RJ45 Ethernet connector (serial interface optional) / SNMP enabled	
Dimensions	17.5" x 9.5" x 8.7" (445 x 242 x 221 mm), not including connectors, isolators, or top screws. See below or contact CPI for detailed outline drawing	
Weight	47 lbs (21.4 kg) typ.	48 lbs (21.8 kg) typ.

160 W Ka-band GaN SSPA/BUC Outline Drawing

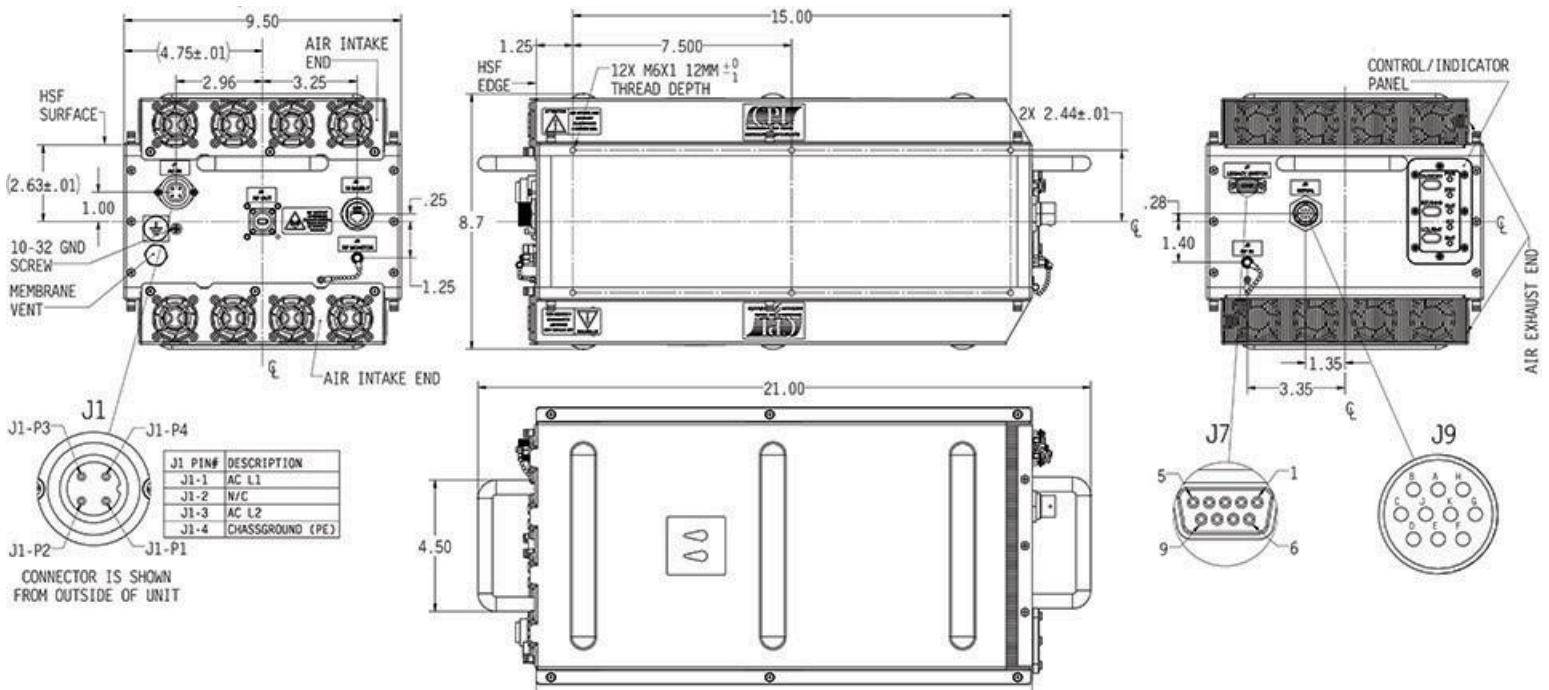

Note: Before using this drawing for planning purposes, please consult CPI to ensure you have the most complete and up-to-date information

10880 Wilshire Blvd Los Angeles CA 90024 USA

Phone: +1.888.315.9545

Email: contact@orbitalconnect.com

<https://store.orbitalconnect.com>

